

Individual Exam

(Sample Questions)

WUCT 2018

The three questions below are meant to give a sense of the kinds of questions that might be asked on the exam in April 2018. The actual exam is 65 minutes long, and it may differ in topic areas covered and difficulty. During the actual exam, necessary constants, equations, and conversions may be found on the last page of this document. Unless otherwise stated, explanations must be written in complete sentences, diagrams must be labeled, and units must be shown in calculations to receive full credit. Please answer the questions in the space provided. No work on the back of the sheets or attached sheets will be graded. The amount of points each question is worth will be indicated on the actual exam. Note that not all lone pairs are necessarily shown on every chemical structure.

Name: _____

High School: _____

Individual

Team ID: _____

1. The following flowchart below outlines the mixture of several chemicals. Each box contains a single chemical, which is combined with another chemical to generate a third chemical. Minor products for each reaction may not be included in the following cell.

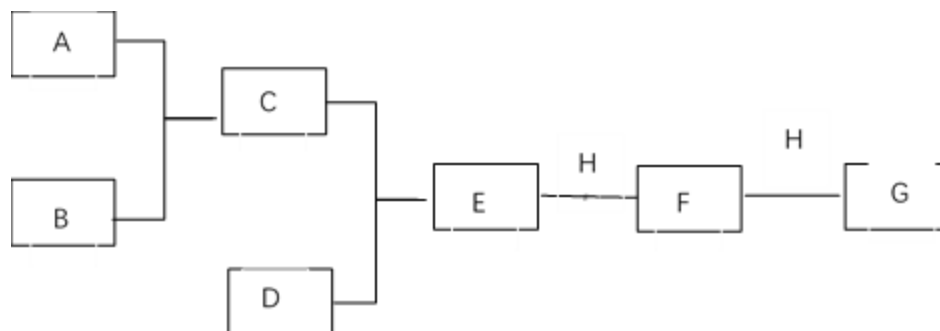

A-H are all common chemicals. A is a reddish-orange metal and C is blue solution. You notice that combining A with B forms a smelly gas. Next, you notice that adding BaCl_2 solution into C solution forms a white precipitate.

- a. According to information above, what might be the possible concentration and chemical formula of B? Please choose the single, most correct answer.
- (1) 8M HCl
 - (2) 1M H_2SO_4
 - (3) 18M H_2SO_4
 - (4) 1M HNO_3
 - (5) 14M HNO_3
- b. Please write down the molecular equation for $\text{A} + \text{B} \rightarrow \text{C}$ (Minor reactants or products may NOT be shown). Which element is oxidized and which element is reduced?
- c. A WUCT Member tried to measure the pH of B with unknown concentration. The member put a drop of B onto a pH paper. Instead of becoming red, the litmus paper was destroyed and turned black.
- i. Could you explain this observation?

Individual

Team ID: _____

- ii. Could you propose a method to determine the concentration of B using pH paper?

- d. Given D is $\text{Al}_{(s)}$, please write down the net ionic equation of $\text{C} + \text{D} \rightarrow \text{E}$. Hint, look at reduction potential charts.

- e. Al is a solid that can react with both acid and base to form $\text{H}_2(\text{g})$. The net ionic equations are:

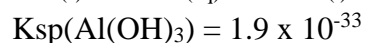
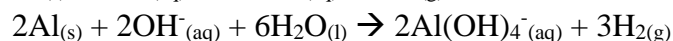
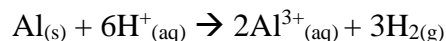

You add chemical H dropwise into solution E, and a white precipitate F is formed. However, as you add more chemical H the precipitate eventually disappears.

- i. Chemical H must contain _____ ions and Chemical F is the _____ precipitate.
- ii. What is the net ionic equation for $\text{E} + \text{H}(\text{excess}) \rightarrow \text{G}$?
- iii. Pretend we wanted to change the direction of the flowchart, and add excess chemical E directly into the solution of chemical H. As chemical E is added drop by drop, describe the change in the appearance of the solution.

Individual

Team ID: _____

- b. D-Luciferin (molar mass = 280.316 g/mol) is the natural substrate for firefly luciferase, one of the key enzymes required for the firefly to produce light. In the following compound, D-Luciferin has combined with a monophosphate nucleotide molecule in a hydrolysis reaction.

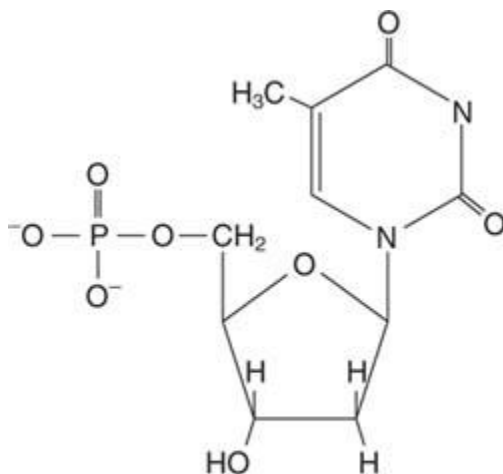
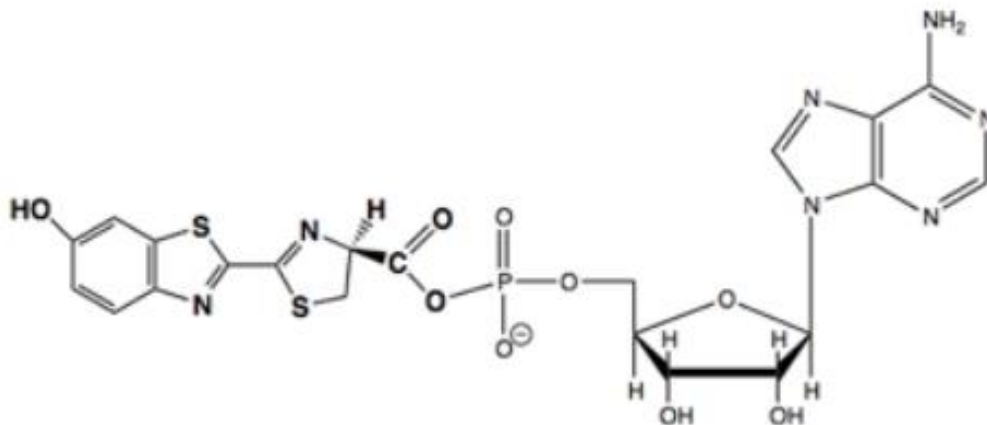

Thymidine Monophosphate,
a Deoxyribonucleotide

- i. What is the chemical formula for D-Luciferin? An image of a monophosphate nucleotide is shown. (Hint: this compound contains a carboxylic acid functional group in its protonated form).

Individual

Team ID: _____

- ii. Based on the structure above, is this molecule more likely to dissolve in substances such as hydrocarbon oils and chloroform vs. polar solvents like water? Explain in terms of intermolecular forces.
 - c. The Mosquito Bioluminescent Bay on the island of Vieques, Puerto Rico is the most bioluminescent in the world. However, instead of fireflies, microscopic dinoflagellates in the bay react to produce a blue-green light emission ($\lambda_{\text{max}} = 495\text{nm}$) for a duration of 0.1s when agitated. What is the power of this light emission?
3. WUCT has been looking to begin production on a side product to help fund its extravagant tournaments. In particular, Stinky Joe has decided that WUCT should begin production of a brand of deodorant called WU-Spice. This will be liquid deodorant in an aerosol bottle.

Individual

Team ID: _____

- a. For a base scent, Stinky Joe wants to add a sweet, woody scent to his perfume. Hexanol ($C_6H_{14}O$, MW 102.2grams/mol)(shown below) has the green, herbaceous fragrance Joe is looking for. The best scent is created when hexanol is 10% of the solution by mass. How many moles of hexanol are needed to make a 100ml bottle of perfume to reach the 10% of hexanol by mass? (assume the density of the solution is 1 g/ml)

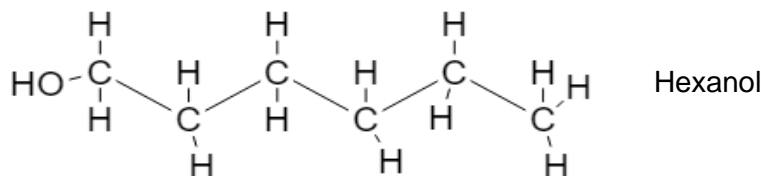

- b. After adding the hexanol, Stinky Joe now wants to add a scent of cauliflower to form the high notes of deodorants, which is remarkably similar to pentane (C_5H_{12})(molecule shown below). After mixing hexanol, pentane, and water, he notices there are two separate layers of fluid. Write the names of the molecules expected in each layer in the figure below.

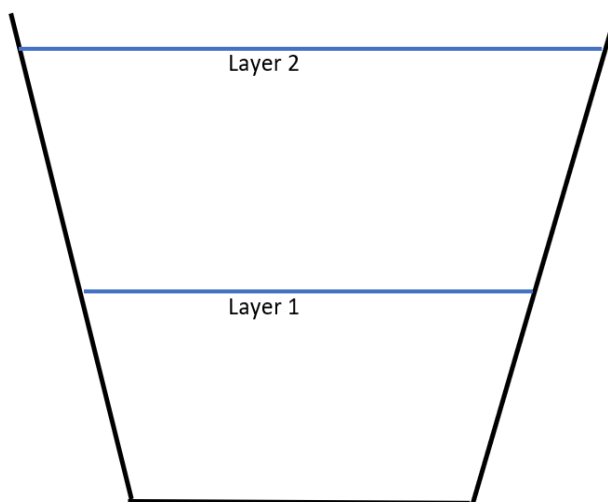
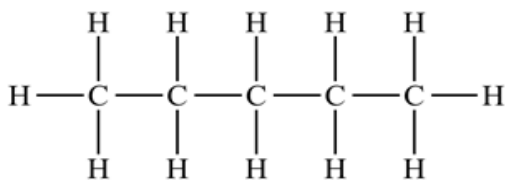

Individual

Team ID: _____

- c. Stinky Joe really likes the smell of rotten eggs underneath his armpits, but is unsettled by the thought of colonies of bacteria living on his body. Therefore, Stinky Joe is considering either adding acetic acid or dodecanethiol to the deodorant to kill bacteria and provide this odor. Assume all bacteria die if the pH is lower than 2.5 or greater than 8.
- i. What concentration of acetic acid ($\text{CH}_3\text{CO}_2\text{H}$) ($K_a = 1.8 \times 10^{-5}$) is needed for the deodorant to have a pH of 2.5? Assume the perfume bottle is filled with only water.
- ii. If Stinky Joe uses dodecanethiol instead of acetic acid to kill the bacteria and make the perfume smell stinky. Because dodecanethiol is basic, Stinky Joe is careful about not adding too much and reduce the acidity of the solution. What concentration of dodecanethiol ($\text{C}_{12}\text{H}_{26}\text{S}$) ($\text{p}K_a = 13.4$) is needed for the deodorant to have a pH of 8.0?

END OF EXAM